

Typical elevation of a SS3 Horizontal Slider.

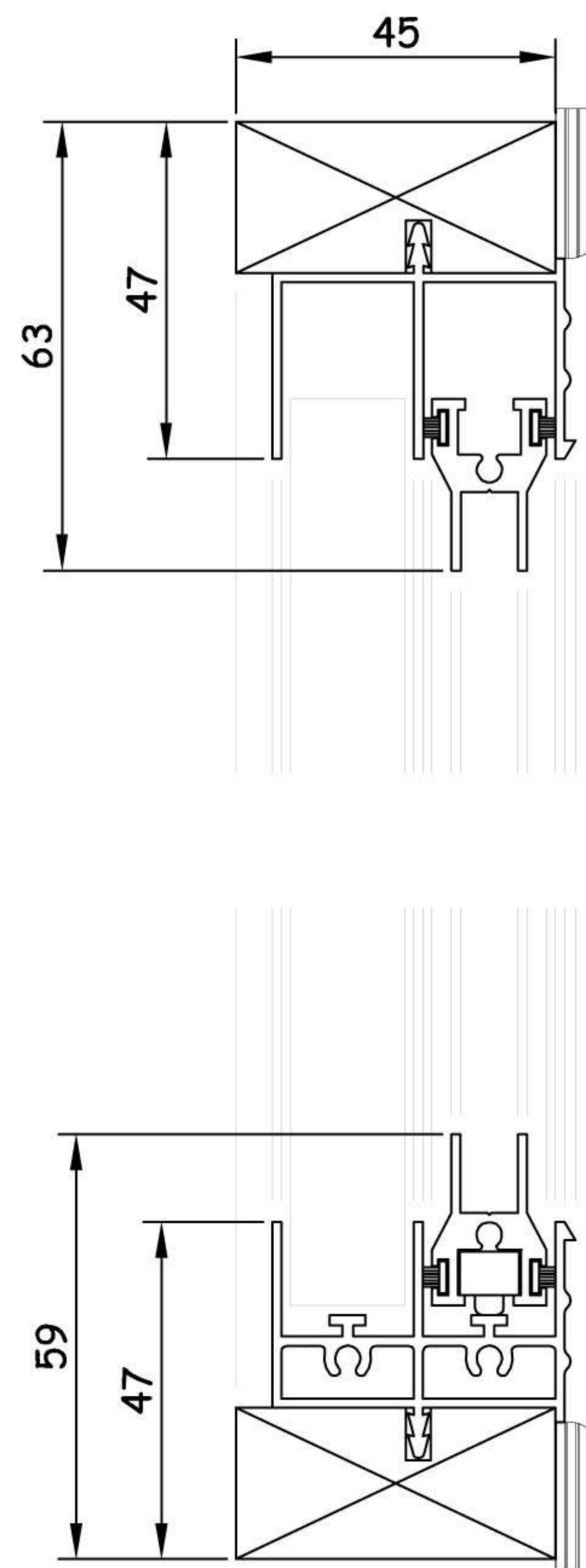

Section through the Horizontal Slider.

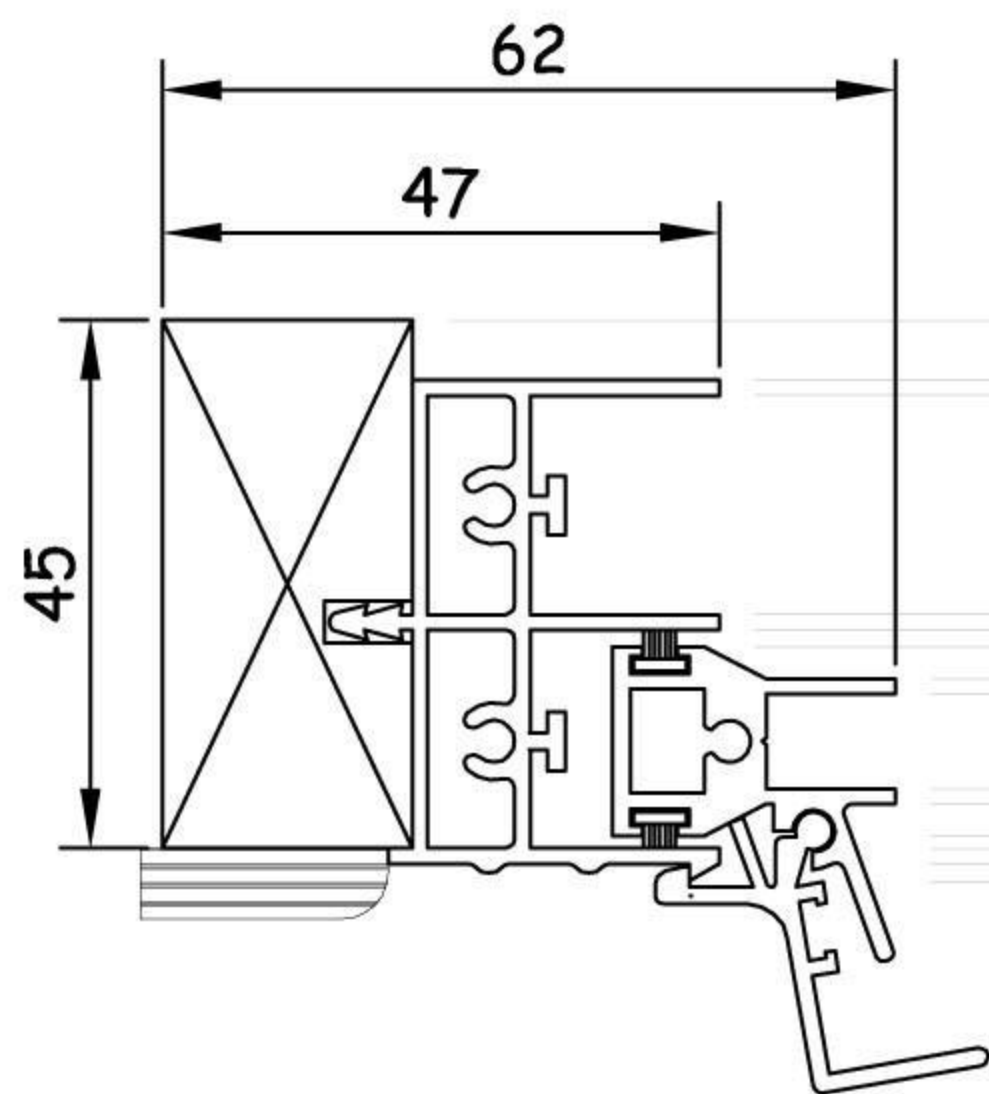

Horizontal Slider Jamb detail.

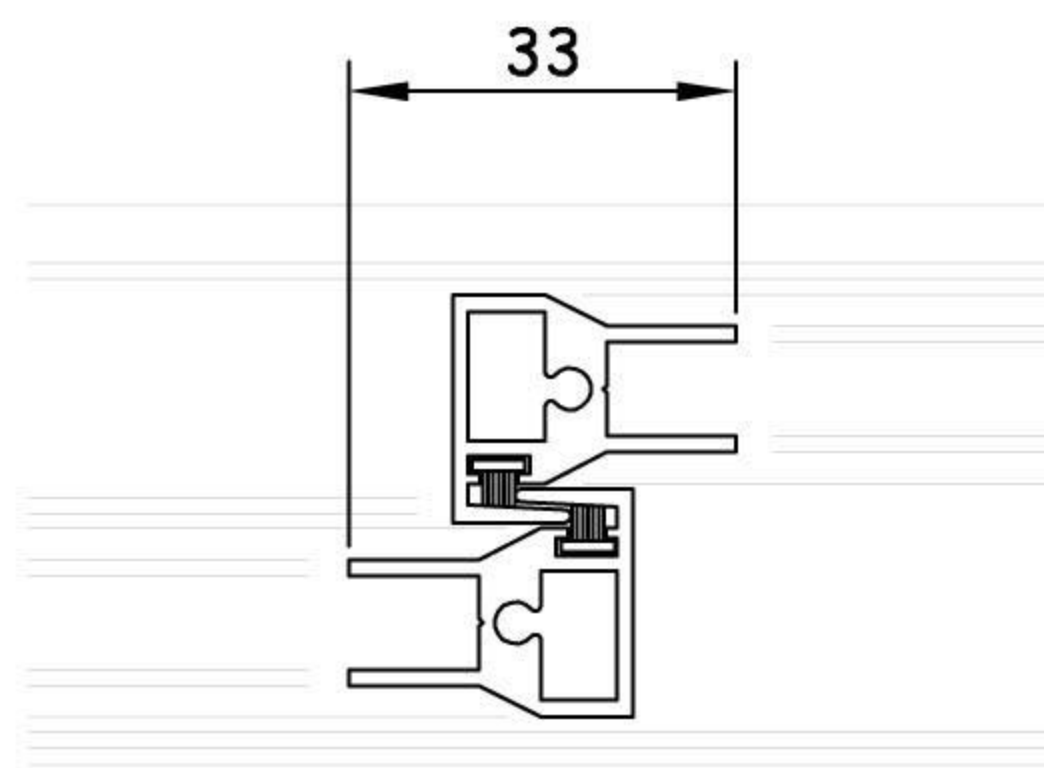

Specification:

Aluminium sections are to be extruded from 6060 alloy EN755-2.
 EP White Gloss - 60 Micron finish.
 All aluminium to be powder coated to BS 6496.
 Frames and sashes are to be mechanically jointed using BZP screws to DIN 7982 - 8 microns.
 The sub-frame is from English hardwood, kiln dried to KD:FAS1F.
 Sub-frames are butt jointed using BZP screws to DIN 965 - 8 microns. Standard sizes 45mm x 21mm & 62mm x 21mm.
 Non-standard sizes are available to order.
 All frames are factory glazed.
 A choice of 4mm or 6mm clear float annealed or toughened.
 6.4mm clear laminate, 6.4mm Acoustic Glass.
 Gaskets are in accordance with BS 2782 in a standard colour of BLACK.
 All sash polypropylene woolpiles are to BS 7386.
 All frames include upvc or timber trim

Revision:

Drg. No. **SS3 FF**

Scale: **1:20 & 1:2** [at A4]

Client:

Drawn by:

Architect:

Date:

Contract: **Standard SS3 Horizontal Slider details.**

Silent Night Secondary Glazing
Protech Direct
(www.secondaryglazing.com)
 Blue Bridge Centre
 Horndale Avenue
 Newton Aycliffe
 Durham
 DL5 6DS
 tel: 01325 310520