

Typical elevation of an SS4 Horizontal Slider.

Section through the Horizontal Slider.

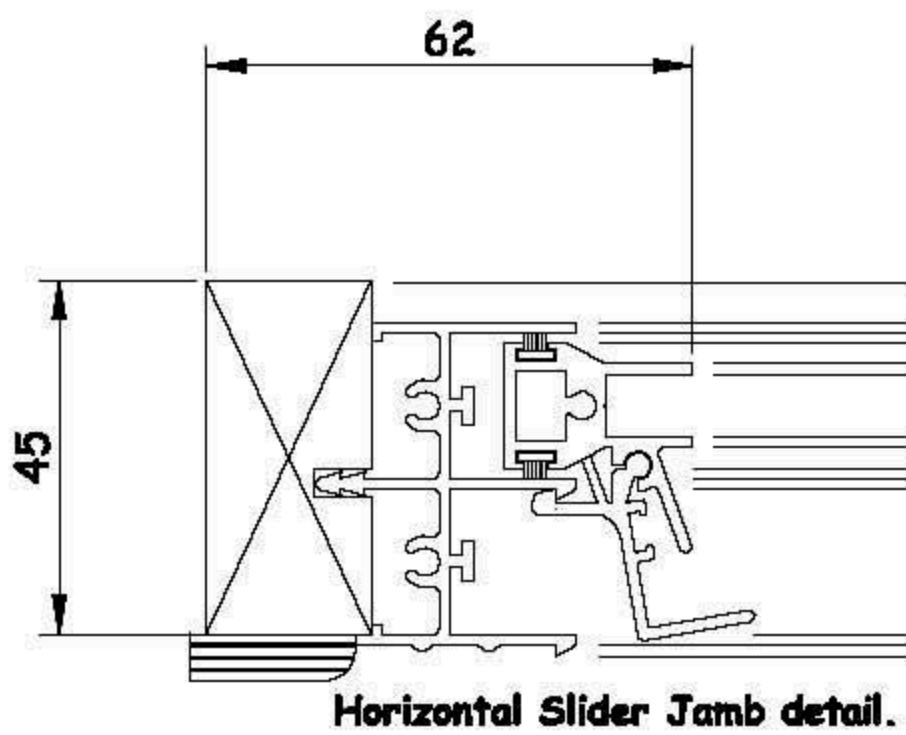

Horizontal Slider Jamb detail.

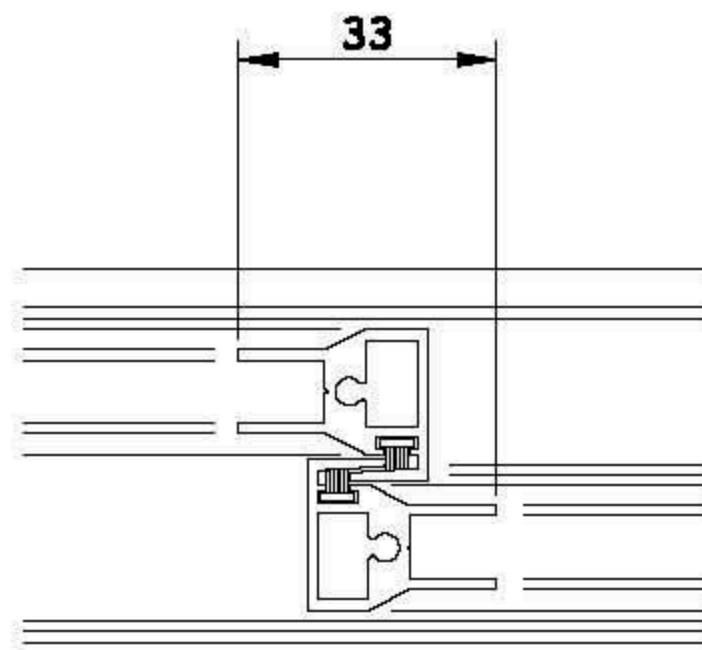

Interlocker details.

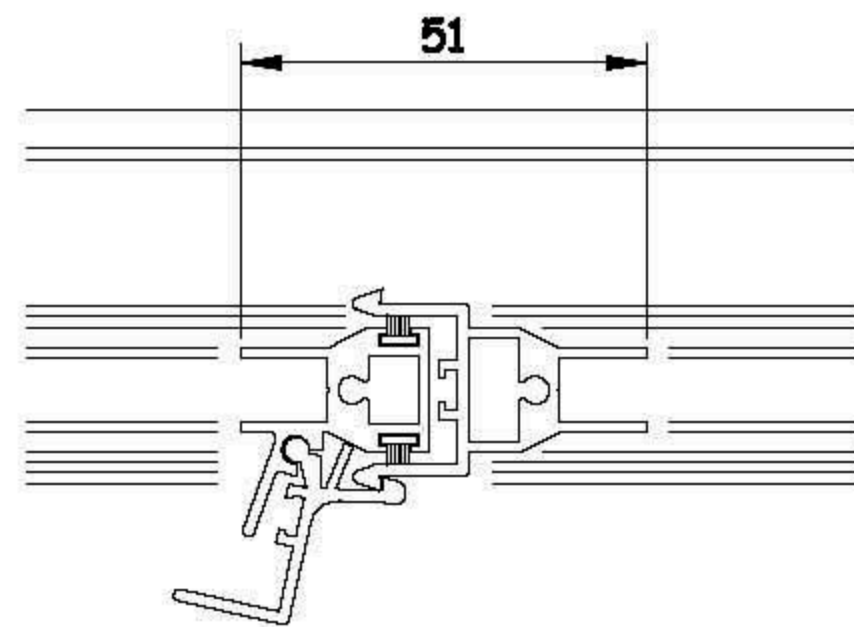

Centre interlocker detail.

Specification:

- Aluminium sections are to be extruded from 6060 alloy EN755-2.
- EP White Gloss - 60 Micron finish.
- All aluminium to be powder coated to BS 6496.
- Frames and sashes are to be mechanically jointed using BZP screws to DIN 7982 - 8 microns.
- The sub-frame is from English hardwood, kiln dried to KD:FAS1F.
- Sub-frames are butt jointed using BZP screws to DIN 965 - 8 microns. Standard sizes 45mm x 21mm & 62mm x 21mm.
- Non-standard sizes are available to order.
- All frames are factory glazed.
- A choice of 4mm or 6mm clear float annealed or toughened.
- 6.4mm clear laminate or 6.4mm Acoustic Glass.
- Gaskets are in accordance with BS 2782 in a standard colour of BLACK.
- All sash polypropylene woolpiles are to BS 7386.
- All frames include upvc or timber trim

Drg. No. SS4 FF	Scale: 1:20 & 1:2 [at A4]	Silent Night Secondary Glazing Protech Direct (www.secondaryglazing.com) Blue Bridge Centre Horndale Avenue Newton Aycliffe Durham DL5 6DS tel: 01325 310520
Client:	Drawn by:	
Architect:	Date:	
Contract: Standard SS4 Horizontal Slider details. Face Fix.		