

Typical elevation of an SS4 Horizontal Slider.

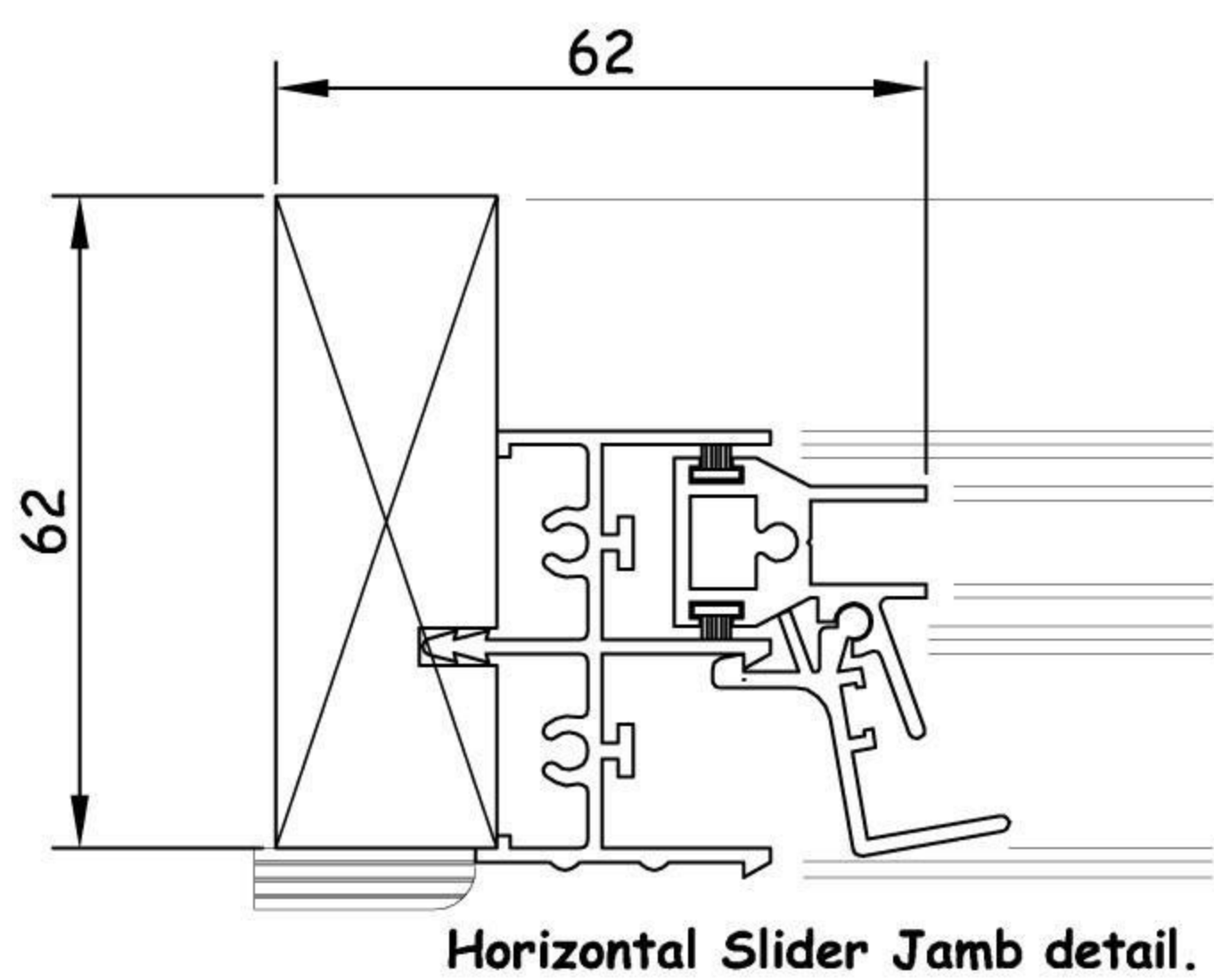

Horizontal Slider Jamb detail.

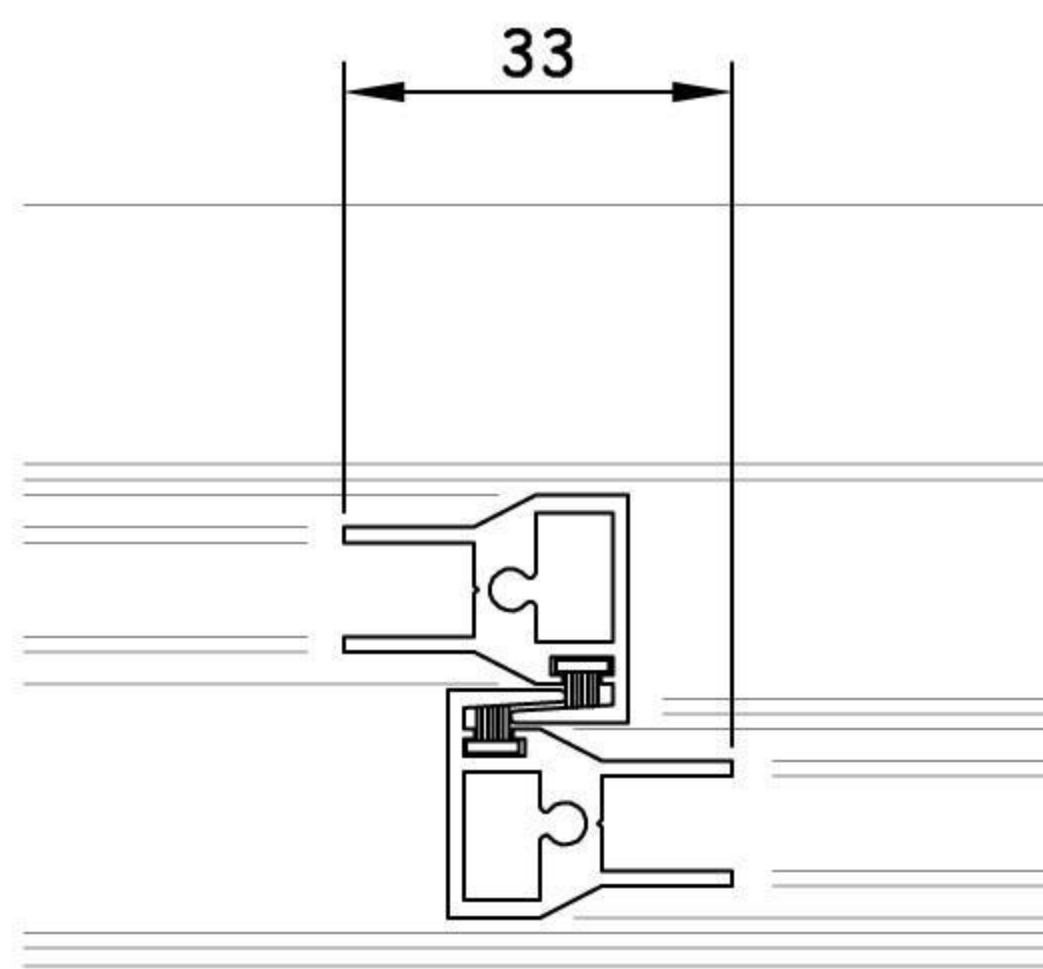

Interlocker details.

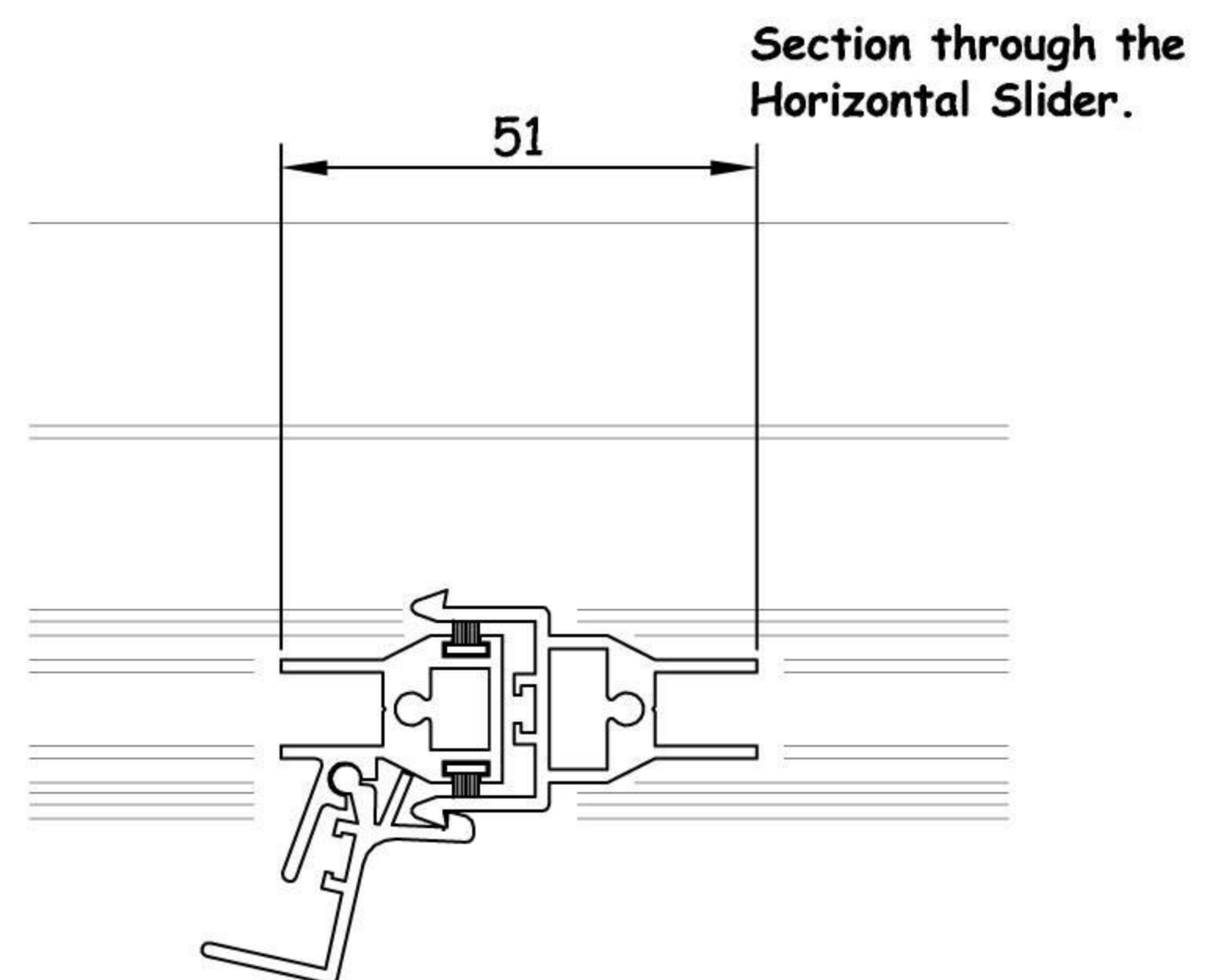

Centre interlocker detail.

Specification:

- Aluminium sections are to be extruded from 6060 alloy EN755-2.
- EP White Gloss - 60 Micron finish.
- All aluminium to be powder coated to BS 6496.
- Frames and sashes are to be mechanically jointed using BZP screws to DIN 7982 - 8 microns.
- The sub-frame is from English hardwood, kiln dried to KD:FAS1F.
- Sub-frames are butt jointed using BZP screws to DIN 965 - 8 microns. Standard sizes 45mm x 21mm & 62mm x 21mm.
- Non-standard sizes are available to order.
- All frames are factory glazed.
- A choice of 4mm or 6mm clear float annealed or toughened.
- 6.4mm clear laminate or 6.4mm Acoustic Glass.
- Gaskets are in accordance with BS 2782 in a standard colour of BLACK.
- All sash polypropylene woolpiles are to BS 7386.
- All frames include upvc or timber trim

Drg. No. SS4 RF	Scale: 1:20 & 1:2 [at A4]
Client:	Drawn by:
Architect:	Date:
Contract: Standard SS4 Horizontal Slider details.	

Silent Night Secondary Glazing
Protech Direct
(www.secondaryglazing.com)
 Blue Bridge Centre
 Horndale Avenue
 Newton Aycliffe
 Durham
 DL5 6DS
 tel: 01325 310520